

1. General Overview of STC15W10x series MCU

1.1 Introduction of STC15W10x series MCU (In abundant supply)

STC15W10x series MCU is a single-chip microcontroller based on a high performance 1T architecture 8051 CPU, which is produced by STC MCU Limited. It is a new generation of 8051 MCU of high speed, high stability, wide voltage range, low power consumption and super strong anti-disturbance. Besides, STC15W10x series MCU is a MCU of super advanced encryption, because it adopts the ninth generation of STC encryption technology. With the enhanced kernel, STC15W10x series MCU is faster than a traditional 8051 in executing instructions (about 8~12 times the rate of a traditional 8051 MCU), and has a fully compatible instruction set with traditional 8051 series microcontroller. External expensive crystal can be removed by being integrated internal high-precise R/C clock($\pm 0.3\%$) with $\pm 1\%$ temperature drift ($-40^{\circ}\text{C}\sim+85^{\circ}\text{C}$) while $\pm 0.6\%$ in normal temperature ($-20^{\circ}\text{C}\sim+65^{\circ}\text{C}$) and wide frequency adjustable between 5MHz and 35MHz. External reset circuit also can be removed by being integrated internal highly reliable one with 16 levels optional threshold voltage of reset.

In Keil C development environment, select the Intel 8052 to compiling and only contain <reg51.h> as header file.

STC15 series MCU with super high-speed CPU core of STC-Y5 works 20% faster than STC early 1T series (such as STC12/STC11/STC10 series) at same clock frequency.

- Enhanced 8051 Central Processing Unit, 1T, single clock per machine cycle, faster 8~12 times than the rate of a traditional 8051.
- Operating voltage range: 5.5V ~ 2.5V.
- On-chip 2K/4K/5K/7K FLASH program memory with flexible ISP/IAP capability, can be repeatedly erased more than 100 thousand times.
- on-chip 128 bytes SRAM
- On-chip EEPROM with large capacity can be repeatedly erased more than 100 thousand times.
- ISP/IAP, In-System-Programming and In-Application-Programming , no need for programmer and emulator.
- Internal highly reliable Reset with 16 levels optional threshold voltage of reset, external reset circuit can be completely removed
- Internal high- precise R/C clock($\pm 0.3\%$) with $\pm 1\%$ temperature drift ($-40^{\circ}\text{C}\sim+85^{\circ}\text{C}$) while $\pm 0.6\%$ ($-20^{\circ}\text{C}\sim+65^{\circ}\text{C}$) in normal temperature and wide frequency adjustable between 5MHz and 35MHz (5.5296MHz / 11.0592MHz / 22.1184MHz / 33.1776MHz).
- **No need external crystal and reset, and can output clock and low reset signal from MCU.**
- Operating frequency range: 0- 35MHz, is equivalent to traditional 8051:0~420MHz.
- UART can be achieved by combining [P3.0/ $\overline{\text{INT4}}$, P3.1] with Timer
- **Support the function of Encryption Download (to protect your code from being intercepted).**
- **Support the function of RS485 Control**
- Code protection for flash memory access, excellent noise immunity, very low power consumption
- Power management mode: Slow-Down mode, Idle mode(all interrupt can wake up Idle mode), Stop/Power-Down mode.
- Timers which can wake up stop/power-down mode: have internal **low-power special wake-up Timer**.

General Overview of STC15W10x series MCU

- Resource which can wake up stop/power-down mode are: INT0/P3.2, INT1/P3.3 (INT0/INT1, may be generated on both rising and falling edges), INT2/P3.4, INT3/P3.5, INT4/P3.0 (INT2/INT3/INT4, only be generated on falling edge); pins T0/T2(their falling edge can wake up if T0/T2 have been enabled before power-down mode, but no interrupts can be generated); internal low-power special wake-up Timer.
- Two Timers/Counters----T0(are compatible with Timer0 of traditional 8051) and T2, T0/T2 all can independently achieve external programmable clock output
- Programmable clock output function(output by dividing the frequency of the internal system clock or the input clock of external pin):

The speed of external programmable clock output of 5V MCU is also not more than 13.5MHz, because the output speed of I/O port of STC15 series 5V MCU is not more than 13.5MHz.

The speed of external programmable clock output of 3.3V MCU is also not more than 8MHz, because the output speed of I/O port of STC15 series 3.3V MCU is not more than 8MHz.

 - ① The Programmable clock output of T0 is on P3.5/T0CLKO (output by dividing the frequency of the internal system clock or the input clock of external pin T0/P3.4)
 - ② The Programmable clock output of T2 is on P3.0/T2CLKO (output by dividing the frequency of the internal system clock or the input clock of external pin T2/P3.1)

Two timers/counters in above all can be output by dividing the frequency from 1 to 65536.

 - ③ The Programmable clock output of master clock is on P3.4/MCLKO, and its frequency can be divided into MCLK/1, MCLK/2, MCLK/4.

The master clock can either be internal R/C clock or the external input clock or the external crystal oscillator.

MCLK is the frequency of master clock. MCLKO is the output of master clock.

It is on MCLKO/P3.4 that the Programmable clock output of master clock of STC15 series 8-pin MCU (such as STC15W10x series). However, it is on MCLKO/P5.4 that the Programmable clock output of master clock of other STC15 series MCU including 16-pin or more than 16-pin MCU(such as STC15F2K60S2, STC15W4K32S4 and so on)
- One 15 bits Watch-Dog-Timer with 8-bit pre-scaler (one-time-enabled)
- advanced instruction set, which is fully compatible with traditional 8051 MCU, have hardware multiplication / division command.
- 6 common I/O ports are available, their mode is quasi_bidirectional/weak pull-up (traditional 8051 I/O ports mode) after reset, and can be set to four modes: quasi_bidirectional/weak pull-up, strong push-pull/ strong pull-up, input-only/high-impedance and open drain.

the driving ability of each I/O port can be up to 20mA, but the current of the whole chip don't exceed this maximum 90mA.

If I/O ports are not enough, it can be extended by connecting a 74HC595(reference price: RMB 0.15 yuan). Besides, cascading several chips also can extend to dozens of I/O ports.
- Package: SOP-8, DIP-8, DFN-8.

General Overview of STC15W10x series MCU

- All products are baked 8 hours in high-temperature 175°C after be packaged, Manufacture guarantee good quality.
- In Keil C development environment, select the Intel 8052 to compiling and only contain < reg51.h > as header file.

1.2 Block diagram of STC15W10x series

The internal structure of STC15W10x series MCU is shown in the block diagram below. STC15W10x series MCU includes central processor unit(CPU), program memory (Flash), data memory(SRAM), Timers/Counters, I/O ports, watchdog, internal high- precise R/C clock, internal hgghly reliable Reset and so on.

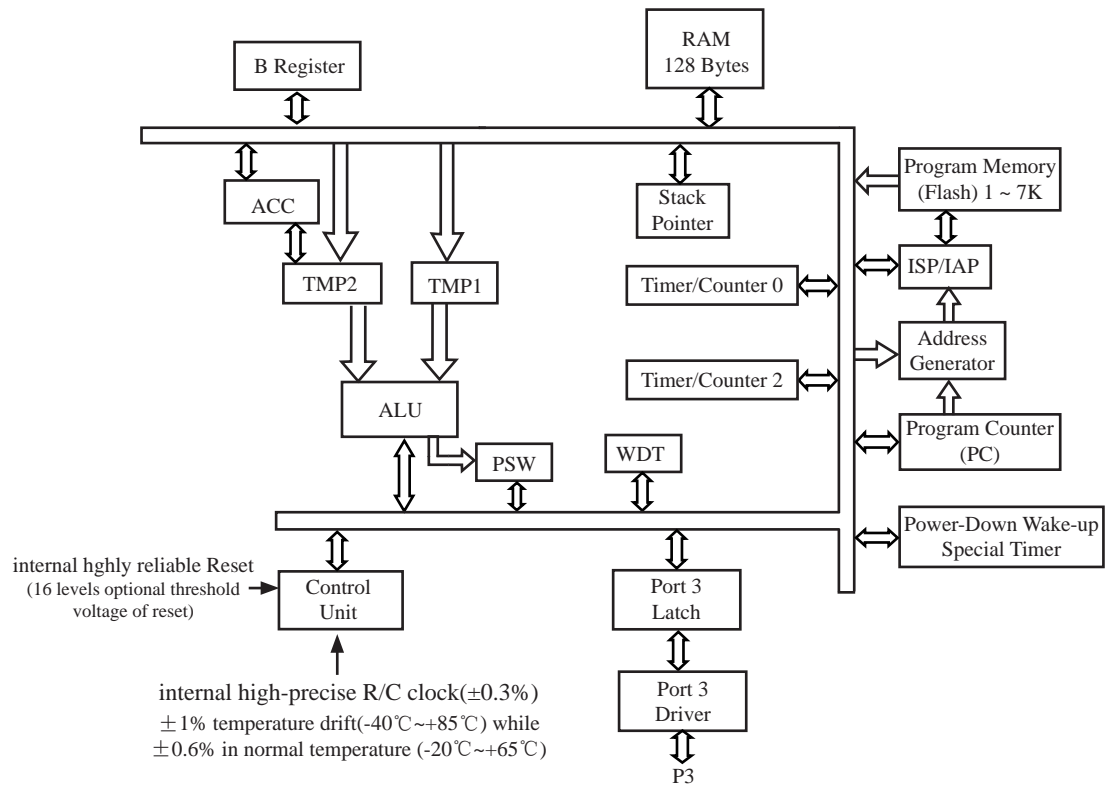

STC15W10x series Block Diagram

General Overview of STC15W10x series MCU

1.3.3 Pin Configurations of STC15W10x series MCU

All packages meet EU RoHS standards

The speed of external programmable clock output of 5V MCU is also not more than 13.5MHz, because the output speed of I/O port of STC15 series 5V MCU is not more than 13.5MHz.

The speed of external programmable clock output of 3.3V MCU is also not more than 8MHz, because the output speed of I/O port of STC15 series 3.3V MCU is not more than 8MHz.

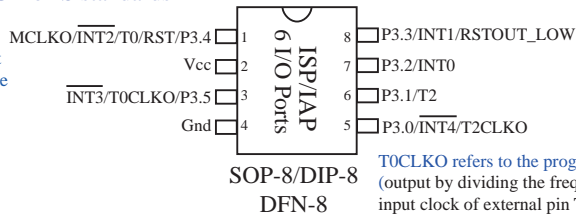

MCLKO is the output of master clock whose frequency can be divided into MCLK/1, MCLK/2, MCLK/4. The master clock can either be internal R/C clock or the external input clock or the external crystal oscillator. MCLK is the frequency of master clock.

T0CLKO refers to the programmable clock output of Timer/Counter 0 (output by dividing the frequency of the internal system clock or the input clock of external pin T0/P3.4);

T2CLKO refers to the programmable clock output of Timer/Counter 2 (output by dividing the frequency of the internal system clock or the input clock of external pin T2/P3.1);

In addition to programmable output on the internal system clock, T0CLKO/T2CLKO also can be used as divider by dividing the frequency of the internal system clock or the input clock of external pin T0/T2.

Mnemonic	Add	Name	7	6	5	4	3	2	1	0	Reset Value
CLK_DIV (PCON2)	97H	Clock Division register	MCKO_S1	MCKO_S0	ADJR	Tx_Rx	Tx2_Rx2	CLKS2	CLKS1	CLKS0	00x0,x000

MCKO_S1	MCKO_S0	the control bit of master clock output by dividing the frequency (The master clock can either be internal R/C clock or the external input clock or the external crystal oscillator)
0	0	Master clock do not output external clock
0	1	Master clock output external clock, but its frequency do not be divided, and the output clock frequency = MCLK / 1
1	0	Master clock output external clock, but its frequency is divided by 2, and the output clock frequency = MCLK / 2
1	1	Master clock output external clock, but its frequency is divided by 4, and the output clock frequency = MCLK / 4

The master clock can either be internal R/C clock or the external input clock or the external crystal oscillator.

MCLK is the frequency of master clock.

STC15104W series MCU output master clock on MCLKO/P3.4

It is on MCLKO/P3.4 that the Programmable clock output of master clock of STC15 series 8-pin MCU (such as STC15W10x series). However, it is on MCLKO/P5.4 that the Programmable clock output of master clock of other STC15 series MCU including 16-pin or more than 16-pin MCU.

Tx_Rx: Setting the external output of P3.1 can reflect the input level state of P3.1 in real time.

0: the external output of P3.1 can not reflect the input level state of P3.1.

1: the external output of P3.1 can reflect the input level state of P3.1 in real time.

CLKS2	CLKS1	CLKS0	the control bit of system clock (System clock refers to the master clock that has been divided frequency, which is offered to CPU and Timers)
0	0	0	Master clock frequency/1, No division
0	0	1	Master clock frequency/2
0	1	0	Master clock frequency/4
0	1	1	Master clock frequency/8
1	0	0	Master clock frequency/16
1	0	1	Master clock frequency/32
1	1	0	Master clock frequency/64
1	1	1	Master clock frequency/128

The master clock can either be internal R/C clock or the external input clock or the external crystal oscillator.

General Overview of STC15W10x series MCU

1.4 STC15W10x series Selection and Price Table

Type 1T 8051 MCU	Operating Voltage (V)	Flash (byte)	SRAM (byte)	U P R T	S P I	common Timers T0/T2	CCP PCA PWM	Speical Power- down Wake-up Timer	Standard External Interrupts	A/D 8-channel	C O M P A R A T O R	D P T R O M	EEP ROM	Internal Low- Voltage Detection Interrupt	W D T	Internal High- reliable Reset (with optional threshold voltage)	Internal High- Precise Clock	Output clock and reset signal from MCU	Encryption Download (to protect your code from being intercepted)	RS485 Control	All Packages SOP-8/DIP-8/ DFN-8 (6 I/O ports)	Price of packages (RMB ¥)	SOP8	DIP8	DFN8		
STC15W10x series MCU Selection and Price Table																											
STC15W100	2.5-5.5	0.5K	128	-	-	2	-	Y	5	-	-	1	-	Y	Y	16-level	Y	Y	Y	Y							
STC15W101	2.5-5.5	1K	128	-	-	2	-	Y	5	-	-	1	4K	Y	Y	16-level	Y	Y	Y	Y							
STC15W102	2.5-5.5	2K	128	-	-	2	-	Y	5	-	-	1	3K	Y	Y	16-level	Y	Y	Y	Y							
STC15W103	2.5-5.5	3K	128	-	-	2	-	Y	5	-	-	1	2K	Y	Y	8-level	Y	Y	Y	Y							
STC15W104	2.5-5.5	4K	128	-	-	2	-	Y	5	-	-	1	1K	Y	Y	16-level	Y	Y	Y	Y							
IAP15W105	2.5-5.5	5K	128	-	-	2	-	Y	5	-	-	1	IAP	Y	Y	16-level	Y	Y	Y	Y							The program Flash in user program area can be used as EEPROM.
IRC15W107 (Fixed internal 24MHz clock)	2.5-5.5	7K	128	-	-	2	-	Y	5	-	-	1	IAP	Y	Y	Fixed	Y	Y	N	N							The program Flash in user program area can be used as EEPROM.

Encryption Download : please burn source code with encryption key onto MCU in the factory. Then, you can make a simple update software just with one "update" button by firstly using the fuction "encyrption download" and then "release project" to update yourself code unabled to be intercepted when you need to upgrade your code.

To provide customized IC services

Because the last 7 bytes of the program area is stored mandatorily the contents of only global ID, the program space the user can actually use is 7 bytes smaller than the space shown in the selection table.

Conclusion: STC15W10x series MCU have: Two16-bit relaodable Timers/Counters that are Timer/Counter 0 and Timer/Counter 2; special power-down wake-up timer; 5 external interrupts INT0/INT1/INT2/INT3/INT4; 1 data pointers ---- DPTR.

1.5 Naming rules of STC15W10x series MCU

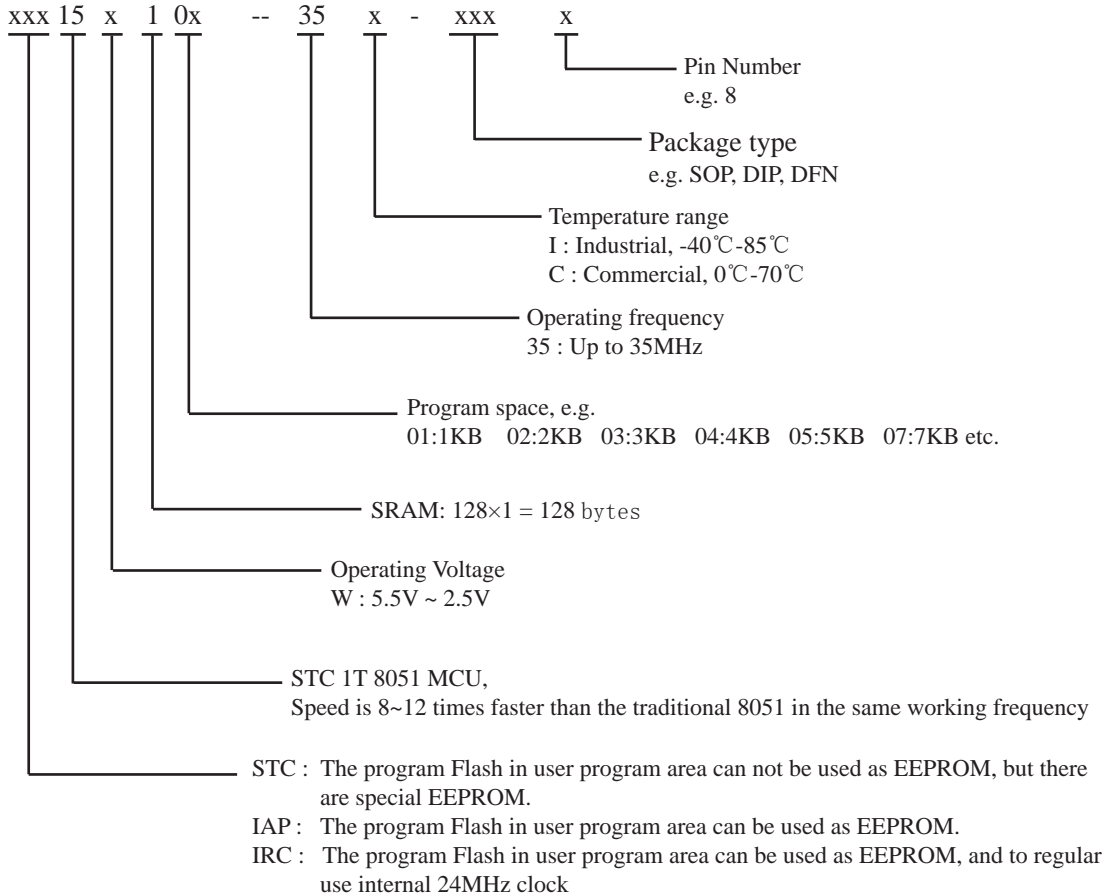

1.6 Application Circuit Diagram for ISP of STC15W10x series MCU

1.6.1 Application Circuit Diagram for ISP using RS-232 Converter

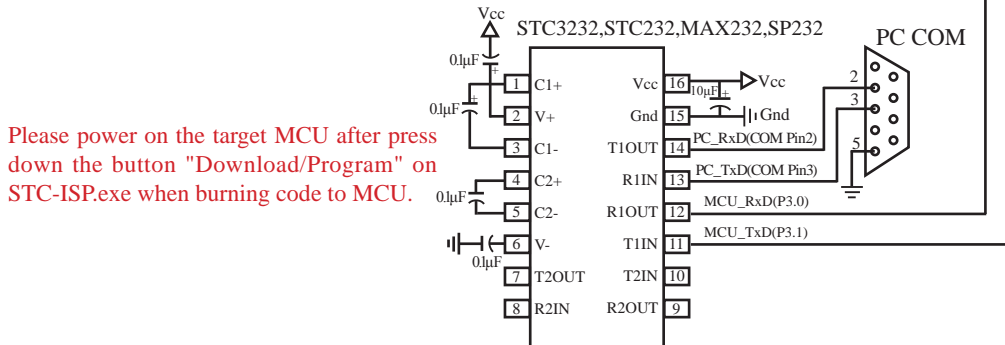
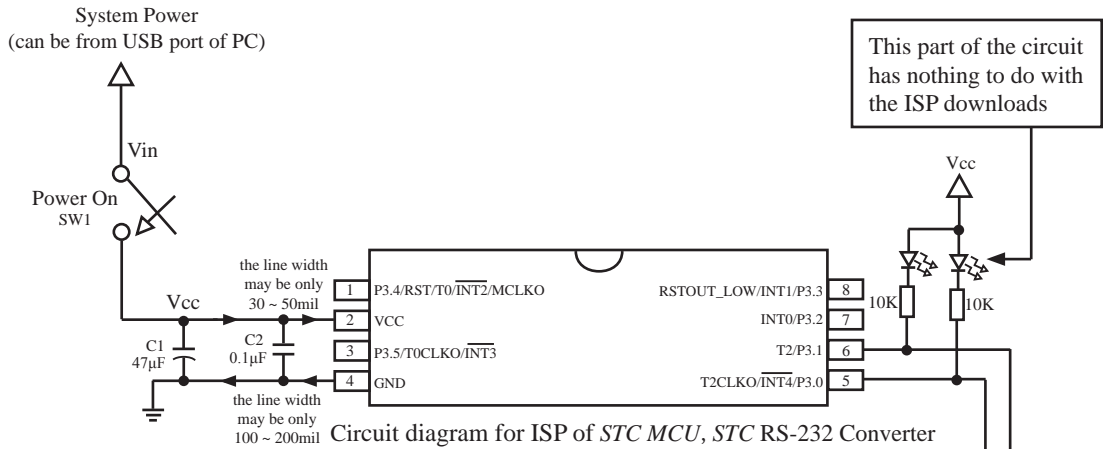

Please power on the target MCU after press down the button "Download/Program" on STC-ISP.exe when burning code to MCU.

Internal highly reliable Reset, External reset circuit can be completely removed.

P3.4/RST/T0/INT2/MCLKO pin factory defaults to the I/O port, which can be set as RST reset pin(active high) through the STC-ISP programmer.

Internal high-precise R/C clock(±3%), ±1% temperature drift (-40°C~+85°C) while ±0.6% in normal temperature (-20°C~+65°C). External expensive crystal can be completely removed.

Recommend to add decoupling capacitor C1(47µF) and C2(0.1µF) between Vcc and Gnd that can remove power noise and improve the anti-interference ability.

General Overview of STC15W10x series MCU

1.6.2 Application Circuit Diagram for ISP using USB Chip PL-2303SA to convert Serial Port

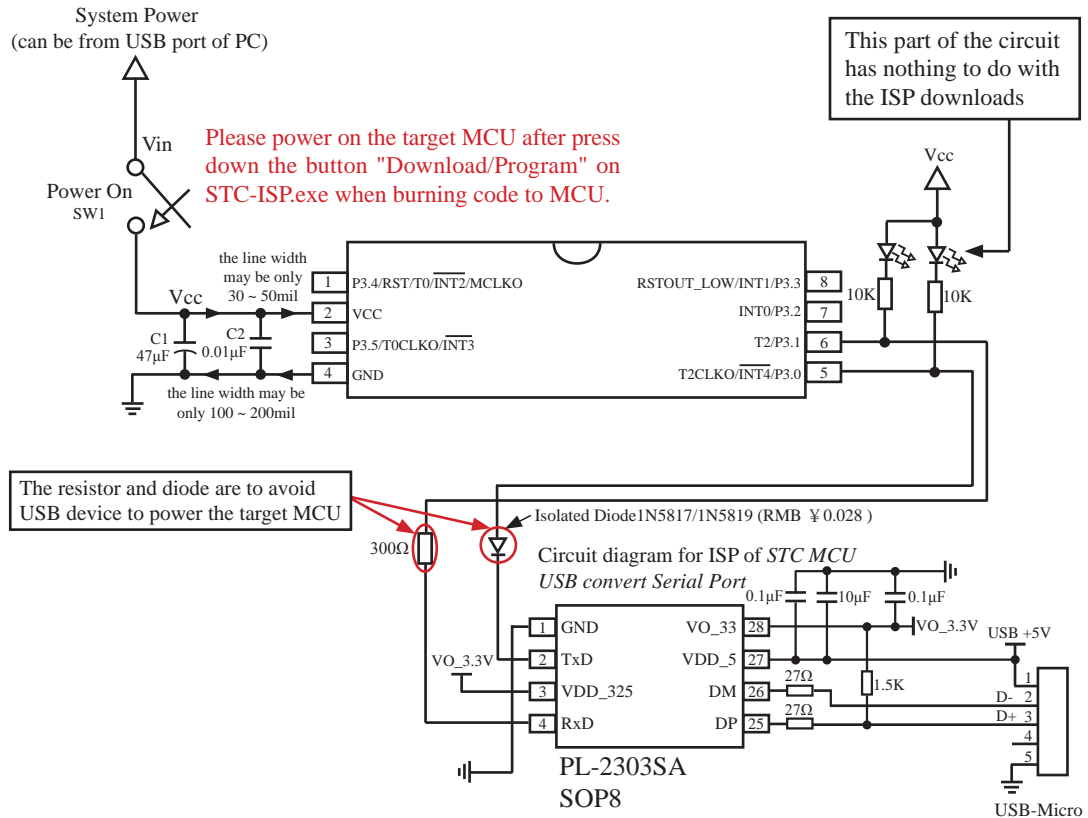

Internal highly reliable Reset, External reset circuit can be completely removed.

P3.4/RST/T0/INT2/MCLKO pin factory defaults to the I/O port, which can be set as RST reset pin(active high) through the STC-ISP programmer.

Internal high-precise R/C clock ($\pm 3\%$), $\pm 1\%$ temperature drift ($-40^{\circ}\text{C} \sim +85^{\circ}\text{C}$) while $\pm 0.6\%$ in normal temperature ($-20^{\circ}\text{C} \sim +65^{\circ}\text{C}$). External expensive crystal can be completely removed.

Recommend to add decoupling capacitor C1(47 μ F) and C2(0.1 μ F) between Vcc and Gnd that can remove power noise and improve the anti-interference ability.

General Overview of STC15W10x series MCU

1.6.3 Application Circuit Diagram for ISP using USB Chip PL-2303HXD / PL-2303HX to convert Serial Port

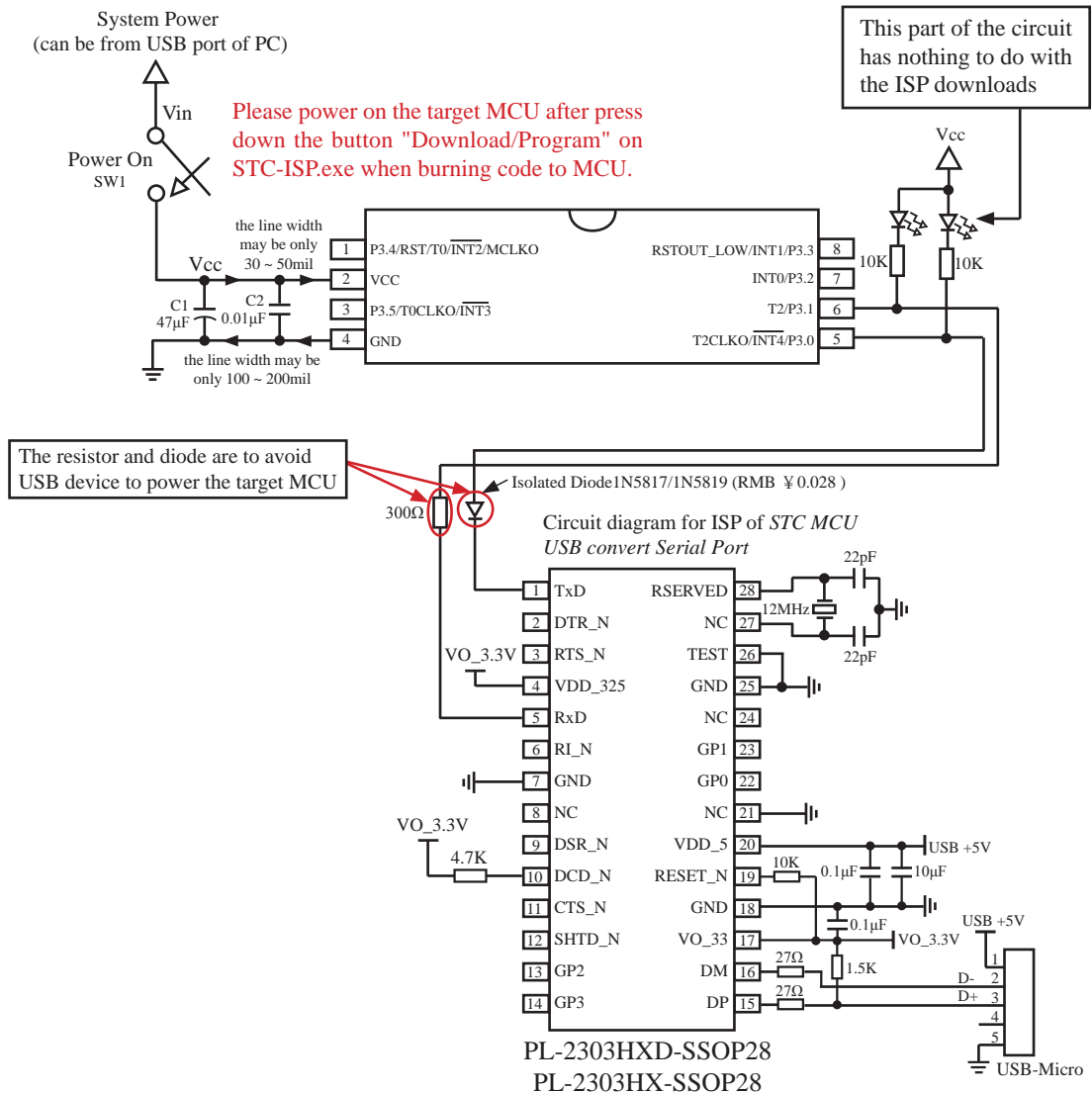

Internal highly reliable Reset, External reset circuit can be completely removed.

P3.4/RST/T0/INT2/MCLKO pin factory defaults to the I/O port, which can be set as RST reset pin(active high) through the STC-ISP programmer.

Internal high-precision R/C clock ($\pm 3\%$), $\pm 1\%$ temperature drift ($-40^{\circ}\text{C}\sim+85^{\circ}\text{C}$) while $\pm 0.6\%$ in normal temperature ($-20^{\circ}\text{C}\sim+65^{\circ}\text{C}$). External expensive crystal can be completely removed.

Recommend to add decoupling capacitor C1(47µF) and C2(0.1µF) between Vcc and Gnd that can remove power noise and improve the anti-interference ability.

1.7 Pin Descriptions of STC15W10x series MCU

MNEMONIC	Pin Number (SOP8/DIP8/DFN8)	DESCRIPTION	
P3.0/ $\overline{\text{INT4}}$ /T2CLKO	5	P3.0	common I/O port PORT3[0]
		$\overline{\text{INT4}}$	External interrupt 4, which only can be generated on falling edge. $\overline{\text{INT4}}$ supports power-down waking-up
		T2CLKO	T2 Clock Output The pin can be configured for T2CLKO by setting INT_CLKO[2] bit /T2CLKO
P3.1/T2	6	P3.1	common I/O port PORT3[1]
		T2	External input of Timer/Counter 2
P3.2/INT0	7	P3.2	common I/O port PORT3[2]
		INT0	External interrupt 0, which both can be generated on rising and falling edge. INT0 only can generate interrupt on falling edge if IT0 (TCON.0) is set to 1. And, INT0 both can generate interrupt on rising and falling edge if IT0 (TCON.0) is set to 0.
P3.3/INT1/ RSTOUT_LOW	8	P3.3	common I/O port PORT3[3]
		INT1	External interrupt 1, which both can be generated on rising and falling edge. INT1 only can generate interrupt on falling edge if IT1 (TCON.2) is set to 1. And, INT1 both can generate interrupt on rising and falling edge if IT1 (TCON.2) is set to 0. INT1 supports power-down waking-up
		RSTOUT_LOW	the pin output low after power-on and during reset, which can be set to output high by software
P3.4/RST/T0/ $\overline{\text{INT2}}$ /MCLKO	1	P3.4	common I/O port PORT3[4]
		RST	Reset pin. A high on this pin for at least two machine cycles will reset the device.
		T0	External input of Timer/Counter 0
		$\overline{\text{INT2}}$	External interrupt 2, which only can be generated on falling edge. $\overline{\text{INT2}}$ supports power-down waking-up
		MCLKO	Master clock output; the output frequency can be MCLK/1, MCLK/2 and MCLK/4. The master clock can either be internal R/C clock or the external input clock or the external crystal oscillator.
P3.5/T0CLKO/ $\overline{\text{INT3}}$	3	P3.5	common I/O port PORT3[5]
		T0CLKO	T0 Clock Output The pin can be configured for T0CLKO by setting INT_CLKO[0] bit /T0CLKO
		$\overline{\text{INT3}}$	External interrupt 3, which only can be generated on falling edge. $\overline{\text{INT3}}$ supports power-down waking-up
Vcc	2	The positive pole of power	
Gnd	4	The negative pole of power, Gound	